

Technical Parameters (技术参数)

	Interior (内胆)	Jacket (夹套)
Material (材质)	SUS304	SUS304
Working pressure (工作压力) Bar	1.5	1.5
Design pressure (设计压力) Bar	3.0	3.0
Tank size (罐尺寸) mm	Ø1560*2700	
Quantity (数量)	1	
Cooling mode (制冷方式)	Alcohol water cooling (乙二醇水制冷)	
Insulation material (保温材料)	Polyurethane (聚氨酯)	
Insulation thickness (保温层厚度) mm	80	
Outer tank thickness (外胆厚度) mm	2.0	
Inter tank thickness (内胆厚度) mm	3.0	
Cover tank thickness (封头厚度) mm	3.0	
Cylinder volume (筒体容积) L	1731	
Cone volume (锥部容积) L	359	
Cover volume (封头容积) L	310	
Effective volume (有效容积) L	2000	
Total volume (总容积) L	2400	

Table of pipe connection (管口表)

NO. (序号)	Size (尺寸)	Purpose (用途)	Connecting style (连接方式)
a	Ø51*1.5	Drainage port (排污口)	Thread (螺纹)
b ₁₋₂	G3/4	Ice water inlet (冰水进口)	Thread (螺纹)
c ₁₋₂	G3/4	Ice water outlet (冰水出口)	Thread (螺纹)
d	Ø38*1.5	Beer outlet (出酒口)	Thread (螺纹)
e	Ø25*1.5	Sampling port (取样口)	Clamp (卡箍)
f	330*430	Manhole door (椭圆人孔门)	Quick-open (快开)
g	Ø38*1.5	CIP port (CIP接口)	Thread (螺纹)
h	Ø38*1.5	Safety valve (安全阀)	Clamp (卡箍)
i	Ø89*1.5	Dry hops adding port (酒花添加口)	Clamp (卡箍)

Specification (规格)

15	Pressure gauge (压力表)	Clamp (卡箍)	Ø38mm	1	SUS304
14	Water-sealed valve (水封阀)	Clamp (卡箍)	Ø38mm	1	SUS304
13	CIP pipe (CIP管)	Clamp (卡箍)	Ø38mm	1	SUS304
12	Level gauge (液位计)	Clamp (卡箍)	/	1	SUS304
11	Cleaning ball (清洗球)	Thread (螺纹)	Ø38mm	1	SUS304
10	Hoisting ring (吊耳)	Welding (焊接)	/	2	SUS304
9	Dished head (蝶形封头)	Welding (焊接)	/	1	SUS304
8	Thermal insulation layer (保温层)	/	80mm	/	PU
7	Manhole door (椭圆人孔门)	Quick-open (快开)	330*430mm	1	SUS304
6	Ice water jacket (冰水夹套)	Welding (焊接)	/	1	SUS304
5	Temperature probe (温度探头)	Thread (螺纹)	/	1	PT100
4	Leg braced (支腿拉撑)	Welding (焊接)	Ø38mm	4	SUS304
3	Supporting leg (支腿)	Welding (焊接)	Ø133mm	4	SUS304
2	Adjusting bolt (调节螺栓)	Thread (螺纹)	M24	4	SUS304
1	Floor (底板)	Welding (焊接)	Ø133mm	4	SUS304
NO.	Name (名称)	Connecting style (连接方式)	Size (尺寸)	Qty (数量)	Material (材料)

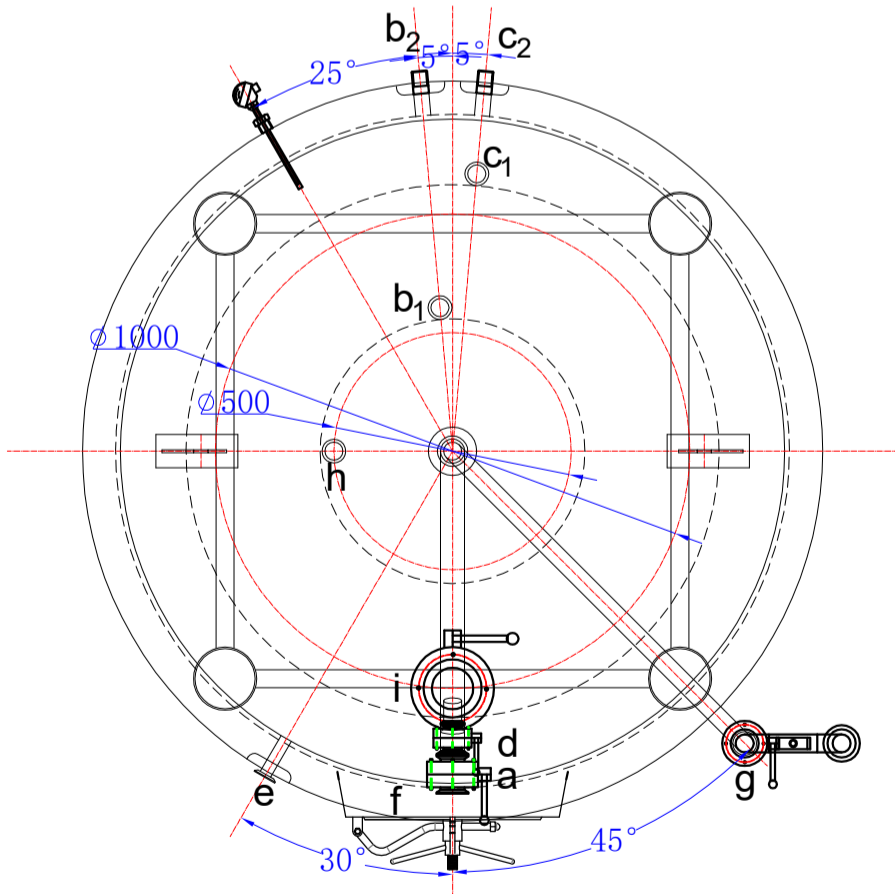
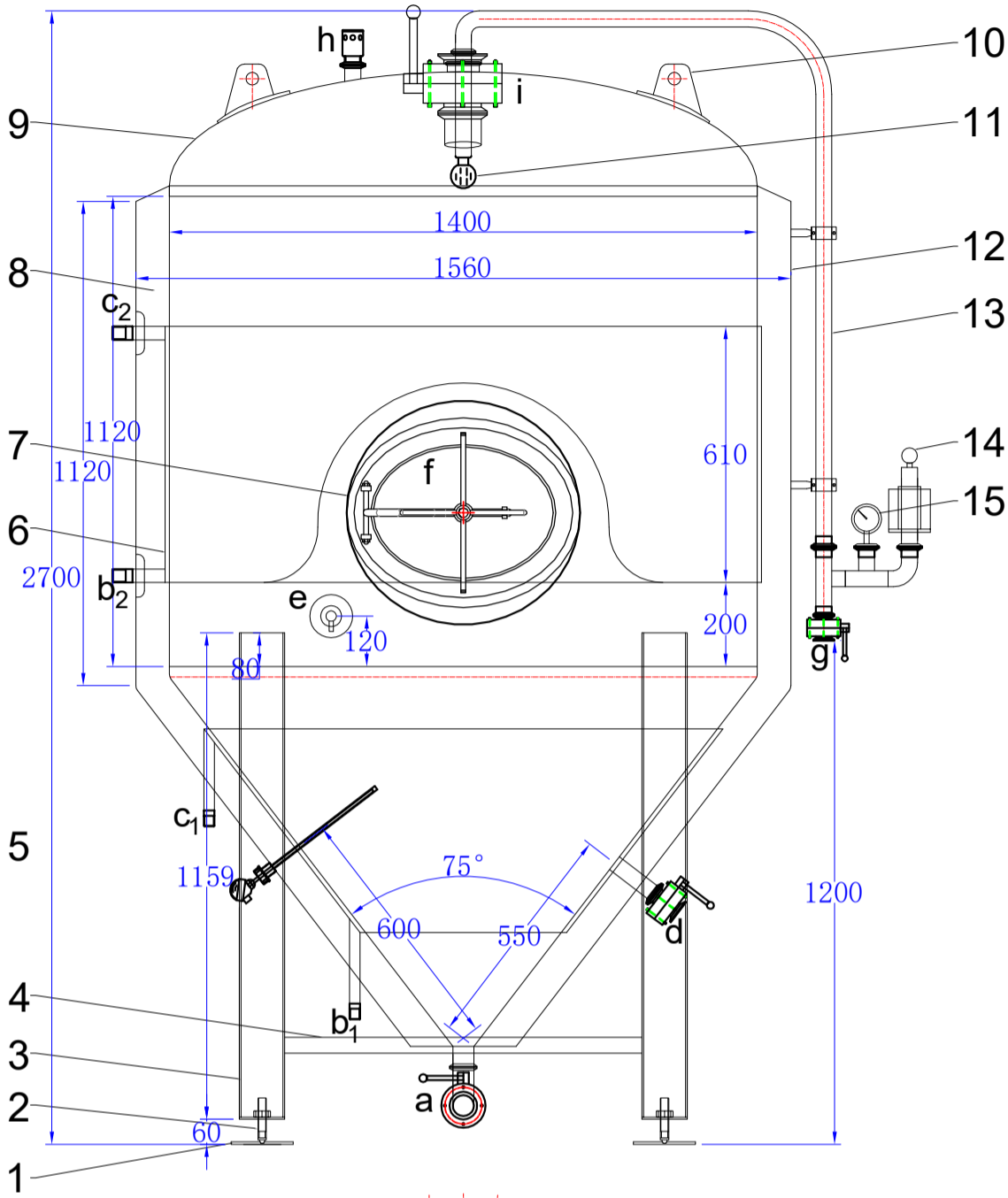

Technique Standards (技术标准):

- 罐体焊缝应保证平齐，不得有凹凸棱角及划痕。
The welding line should be smooth and tidy, concave & convex edges and scratches are not allowed.
- 焊缝抛光到Ra小于0.8微米
The polishing accuracy of welding line should be $<0.8\mu\text{m}$
- 制造完毕后，设备内及夹套打压检漏，压力3.0Bar 保持24小时
After finished, the whole tank and jackets should be tested by filling air, keeping 24 hours with 3Bar pressure.

设计			2000L 发酵罐	
校对			2000L Fermentation tank	
审核			重量	订单编号
批准			共张第张	日期